

G.H. Rigby & Sons Limited

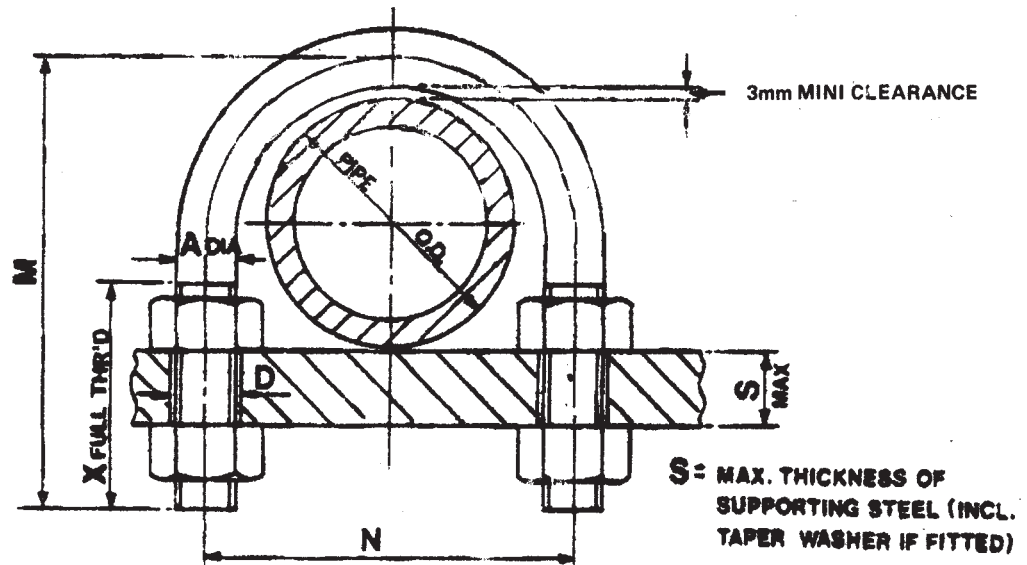

ALL DIMENSIONS IN MILLIMETRES UNLESS STATED OTHERWISE



U BOLT DIMENSIONS							
NOM SIZE	O.D	A DIA	N	M	X	S MAX	HOLE DIA
1/2	21.3	8	40	45	25	7	10
3/4	26.7	8	45	55	30	10	10
1	33.4	8	50	60	30	10	10
1 1/2	48.3	10	65	85	40	16	12
2	60.3	10	80	100	40	16	12
3	88.9	16	110	140	55	19	19
4	114.3	16	140	165	55	19	19
6	168.3	20	195	225	65	19	24
8	219.1	20	250	275	65	19	24
10	273	20	305	335	75	22	24
12	323.9	20	355	385	75	22	28
14	355.6	24	390	425	80	22	28
16	406.4	24	440	475	80	22	28
18	457.2	24	495	525	80	22	28
20	508	24	545	575	80	22	28
22	550.8	24	595	625	80	22	28
24	609.6	24	645	675	80	22	28

Zinc Electro plated
To BS 3383 Pt. 2.

MATERIALS+
U BOLT BS 4360 Grade 43A
NUTS BS 4190 Grade 4
THREADS BS 3643 Part 2 C1.3

To order this standard
Quote U BOLT NG and diameter.

PIPE SUPPORTS
U BOLTS (NOT TO GRIP PIPE) CARBON STEEL
FOR STEEL PIPE.
BS 3974 Part 1