

PIPE SUPPORT

SK06

WELD-ON SKID WITH ANTI-FRICTION BAR
LAGGED OR UNLAGGED CARBON STEEL PIPE;
NPS 1/2 TO NPS 6

Specifications

Skid and guides: carbon steel to BS 4360 Grade 43 A
Sole plate: austenitic steel to BS1449: Part 2 Grade 304515 or 304531
Carbon steel surfaces to be protected after fabrication by a paint finish to be agreed.
ISO metric bolts to BS 4190 Gr 4.6; ISO metric nuts to BS 4190 Gr 4
Nuts and bolts to be zinc electro plated to BS 3382: Part 2

All dimensions in millimetres unless otherwise stated

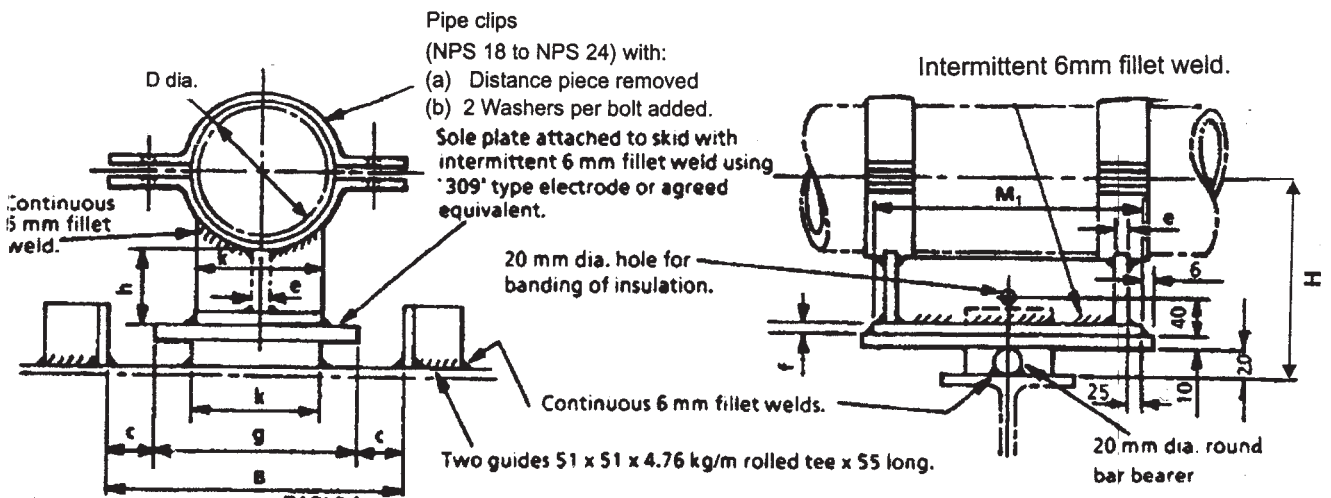

TABLE 1

Pipe		Outside Diameter	e	f	k	H	h	Austenitic Steel Sole Plate
D Nom Size	NPS							
8	200	219.1	10	12	200	290	140	M ₁ + 12 mm x g mm x 10mm THICK
10	250	273.1	10	12	200	317	140	
12	300	323.9	10	12	200	342	135	
14	350	355.6	12	15	300	358	135	
16	400	406.4	12	15	300	384	130	
18	450	457.0	15	18	300	409	130	
20	500	508.0	15	18	400	434	125	
22	550	558.8	15	18	400	460	125	
24	600	610.0	15	18	400	485	125	

TABLE 2

c	NPS 8, 10 & 12		NPS 14, 16 & 18		NPS 20, 22 & 24	
	g	B	g	B	g	B
5	230	240	330	340	430	440
10	240	260	340	360	440	460
15	250	280	350	380	450	480
20	260	300	360	400	460	500
25	270	320	370	420	470	520
30	280	340	380	440	480	540
35	290	360	390	460	490	560
40	300	380	400	480	500	580
45	310	400	410	500	510	600
50	320	420	420	520	520	620

To order this standard, Quote SK06 / D / B / M1.