

PIPE SUPPORT

SK04

WELD-ON SKID WITH OR WITHOUT GUIDES
LAGGED OR UNLAGGED CARBON STEEL PIPE;
NPS 8 TO NPS 24

Specifications

Skid and guides; carbon steel to BS 4360 Grade 43 A
Skid to be hot dipped galvanised to BS729, unless used with stainless steel pipe.
ISO metric bolts to BS 4190 Gr 4.6; ISO metric nuts to BS 4190 Gr 4. Washers to BS4320 table 3.
Nuts and bolts to be zinc electro plated to BS 3382: Part 2.

All dimensions in millimetres unless otherwise stated

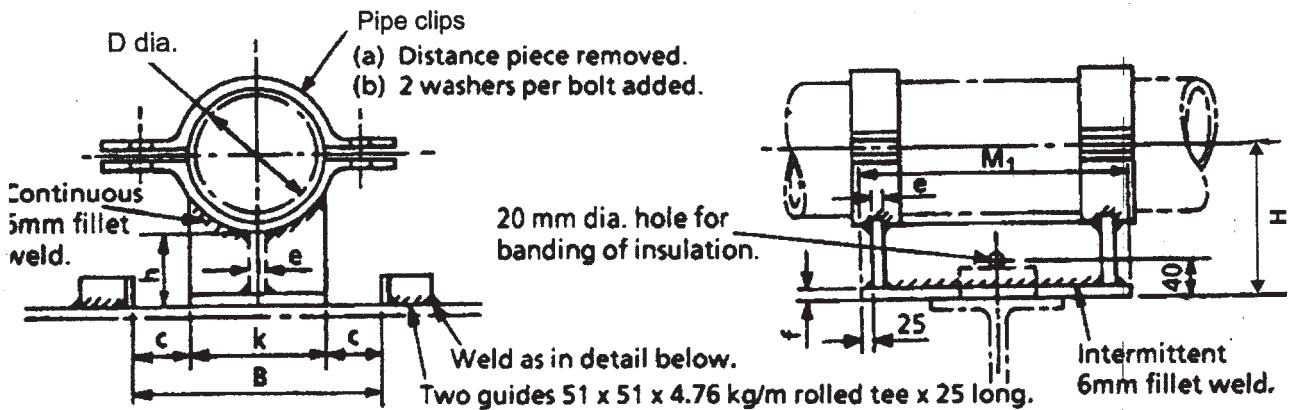

Pipe		Outside Diameter	e	f	k	H	h
D Nom Size	DN						
8	200	219.1	10	12	200	260	140
10	250	273.1	10	12	200	287	140
12	300	323.9	10	12	200	312	135
14	350	355.6	12	15	300	328	135
16	400	406.4	12	15	300	354	130
18	450	457.0	15	18	300	379	130
20	500	508.0	15	18	400	404	125
22	550	558.8	15	18	400	430	125
24	600	610.0	15	18	400	455	125

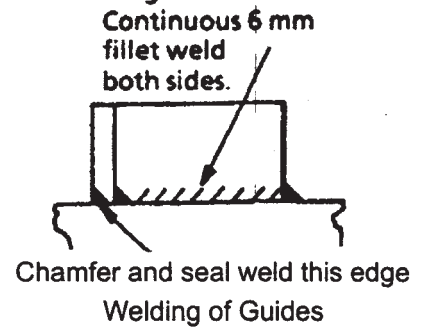

To order this standard, Quote SK04 / D / B / M1.