

PIPE SUPPORT

SK02

WELD-ON SKID WITH OR WITHOUT GUIDES
LAGGED OR UNLAGGED CARBON STEEL PIPE;
NPS 8 TO NPS 24

Specifications

Skid and guides; carbon steel to BS 4360 Grade 43 A

All dimensions in millimeters unless otherwise stated

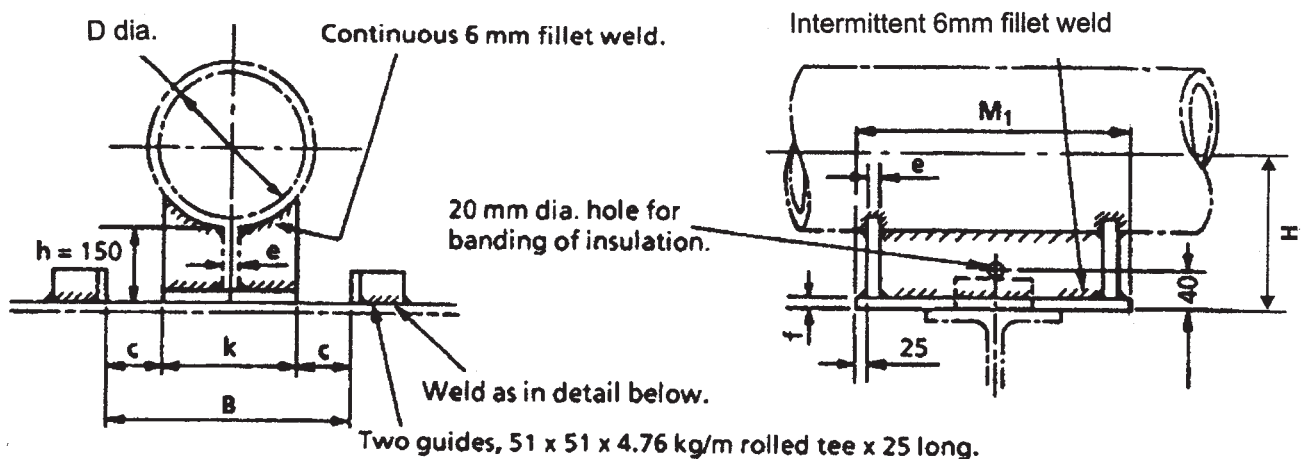

Pipe		Outside Diameter	e	f	k	H
D Nom Size	DN					
8	200	219.1	10	12	200	260
10	250	273.1	10	12	200	287
12	300	323.9	10	12	200	312
14	350	355.6	12	15	300	328
16	400	406.4	12	15	300	354
18	450	457.0	15	18	300	379
20	500	508.0	15	18	400	404
22	550	558.8	15	18	400	430
24	600	610.0	15	18	400	455

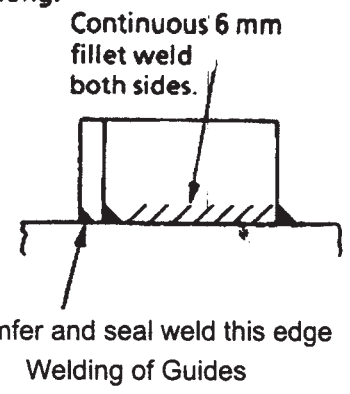

To order this standard, Quote SK02 / D / B / M1.